

TruLaser Tube

Tubes prefer
TRUMPF

Accelerate growth with laser tube cutting

The world we live in is growing. And with it the demand for products in a large scale and in a wide range of materials. Tubes are an fundamental part of this. With high growth rates, the market for laser-cut tubes offers exceptionally good chances of success. Choose laser tube cutting to stay on the cutting edge in the future.

The possibilities of technology

We are living in a world of tubes
4–5

Advantages compared with conventional tube cutting

Why process tubes with lasers?
6–7

Flexible and cost-efficient manufacturing

Redesign and save on costs
8–9

The right software

Your product range for the world of tubes
10–11

Integrated components for best results

Functions that take you forward
12–13

The TruLaser Tube family

The right machine for you
14–27

There for you: our services

TruServices.
Your Partner in Performance
28–29

Networked production

TruConnect –
Your Smart Factory
30

We are living in a world of tubes

What does an intricate designer lamp share with the sturdy frame of a combine harvester or the complex tubular system of a scaffold? They are all produced from laser-cut tubes and profile designs. No wonder, because no tool is as versatile and offers as much contouring freedom as a laser. You can find evidence of it in furniture, cars, commercial vehicles, transportation, on construction sites, in mechanical engineering, plant construction, in agriculture, in the fitness industry, climate and energy technology, or in shelf manufacturing.





Why process tubes with lasers?

No need for sawing, drilling, or deburring: Compared to conventional tube cutting, the laser replaces a number of work steps. It can cut complex contours very precisely in materials such as mild steel, stainless steel, aluminum, or nonferrous metal. Laser tube cutting offers a wide range of design options - opening the door to new products, customers, and orders.



"Laser tube cutting offers new design options for tube manufacturers to delight their customers. Innovative designs also offer a great potential for savings."

Norbert Beier, Head of Sales Laser Tube Cutting



Make full use of versatile contouring options

You can cut every conceivable contour with a laser beam. At the same time, machines are easy to use – your design options are almost unlimited.

Cost-effective manufacturing

Carry out several different work steps on a single machine, manufacturing parts precisely and quickly.

Save on tools

With laser, you can process different types of materials, thicknesses, and profile geometries in a completely noncontact operation. It saves time and money as there is no need to change tools.

Comparison of work steps for laser tube cutting and conventional production

Conventional production

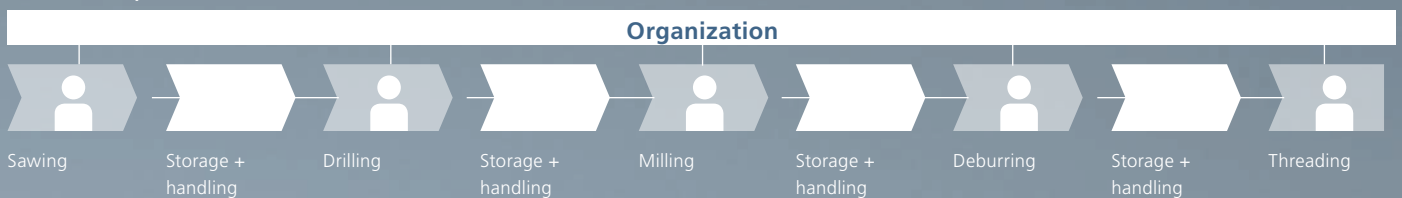

Laser tube cutting



Redesign and save on costs

Innovative tube designs save time and give you the technical edge: With bending frames, for example, you will need fewer parts. Positioning aids facilitate error-free assembly. The amount of work required for downstream work steps, such as welding, is noticeably reduced. And all this with just one machine.

How can you optimize your parts? Speak with our expert consultants on parts design to receive a wide range of tips that are tailored to your exact needs. Ready for optimal parts design?

Easier positioning, connecting and assembling

Clever designs with laser tube cutting simplify your processes: prepare your parts perfectly for subsequent work steps.

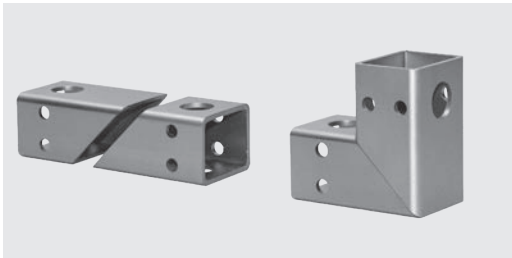

Thanks to bevel cuts of up to 45°, you can further process corner connections more quickly – with optimal material utilization.



Use tube-blank connections for simple fixings, optionally with lugs or coding function.

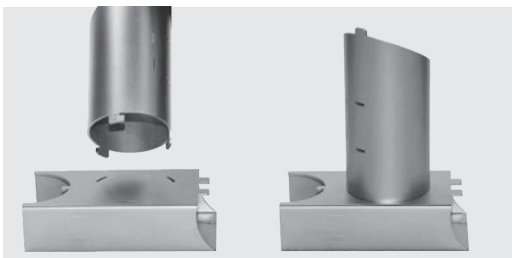

Replace time-consuming welding fixtures with plugs, dovetails, and bayonet connections.

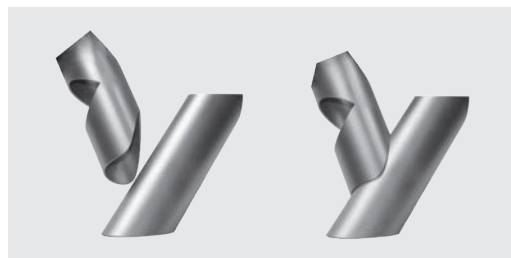

Connect tubes together easily using attachments – the perfect option for load-carrying tube designs.



Conventionally welded from two single parts.

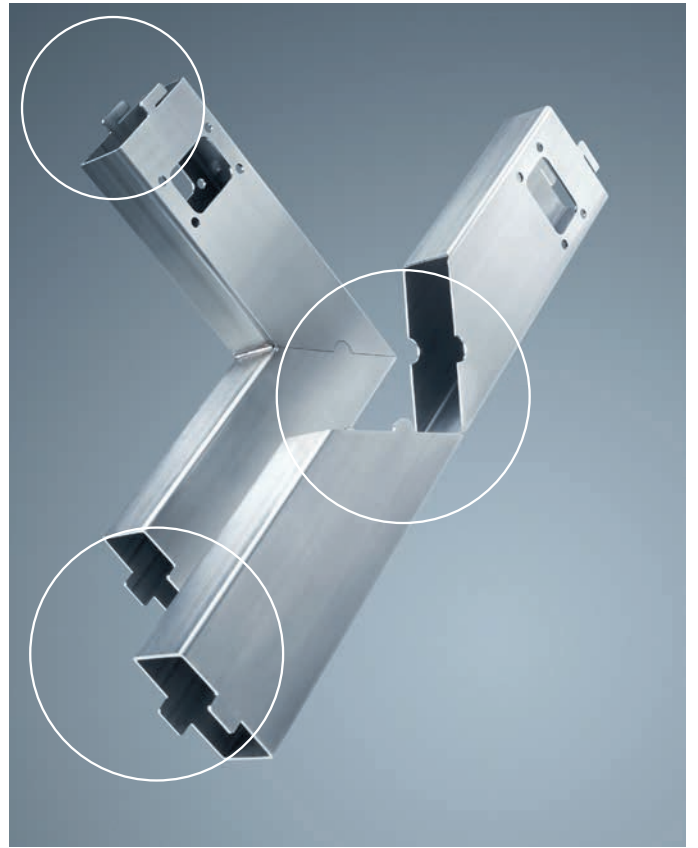

Efficient production of bend connections and positioning aids with a laser.

Increased technical advantages, reduced parts costs

Get straight to the bottom line: thanks to bend connections, recesses, and pins, you can reduce the time needed to make this sample part by 49% and the cost by 31%.

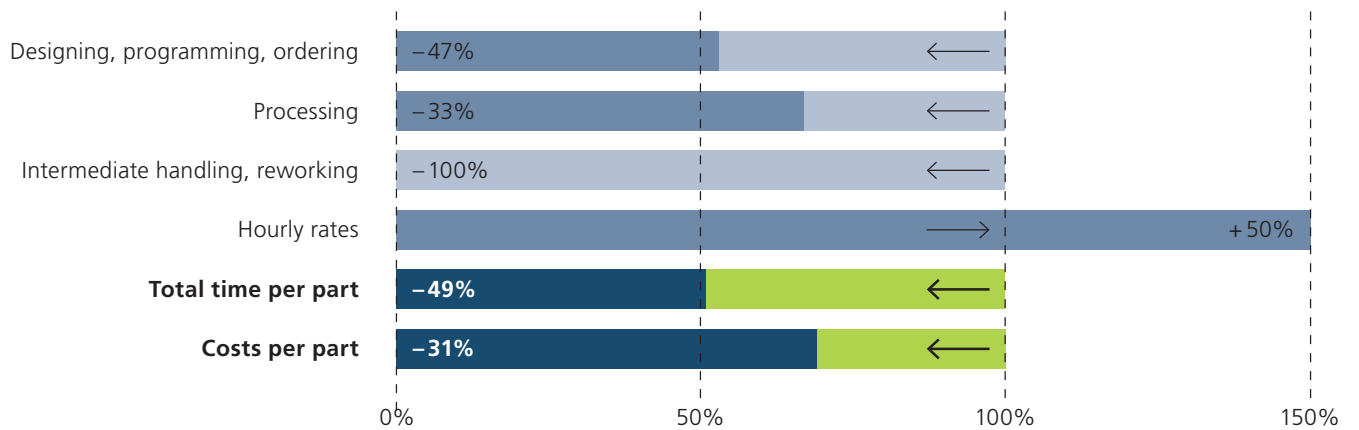

Laser tube cutting with TruLaser Tube

Conventional production (sawing, milling, drilling)

Your product range for the world of tubes

The 3D software Programming Tube takes you quickly, easily, and intuitively to the NC program. Thanks to vigorous automatization, no programming is required for many finished parts. Numerous presets, such as automatic production of innovative bend connections and positioning aids, are already stored. The software solution also offers flexible data import and powerful design, supporting you throughout the entire programming process.

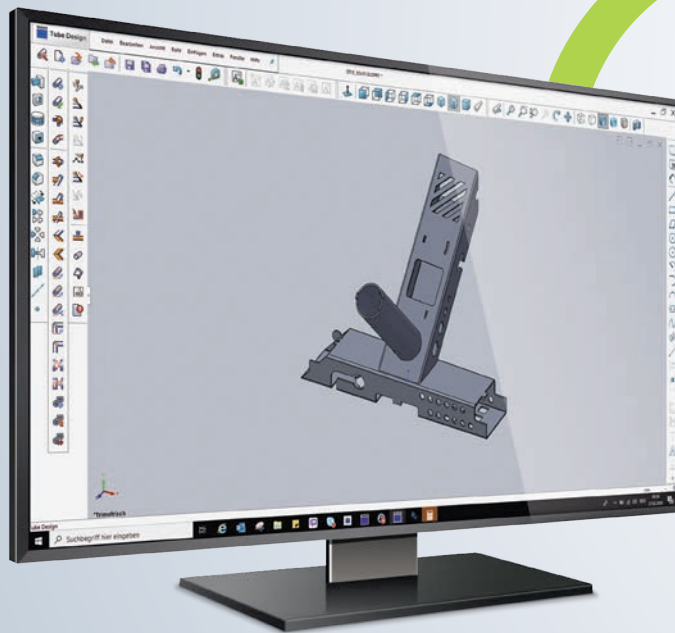

Programming Tube

- Programming system for tube and profile processing
- Strong automatism: Parts already programmed when loading
- Easy to learn thanks to modern, intuitive user interface
- Direct manipulation: Change processing directly in 3D
- Optimize parameters in the running simulation
- Preset rules and TRUMPF cutting data

Automatic programming of threads

Based on the thread parameters, Programming Tube automatically creates the NC program including tools and processing sequence.

Flexible data imports

Import all common formats in Programming Tube. The program corrects incorrect data as well as rounding radii and splits up their assemblies.

Adding tube connections

Design positioning aids and bend connections with just a few clicks of the mouse and reduce your rejects. Positioning aids simplify downstream work steps such as mounting or welding. Bend connections help you to connect tubes more precisely and quickly.

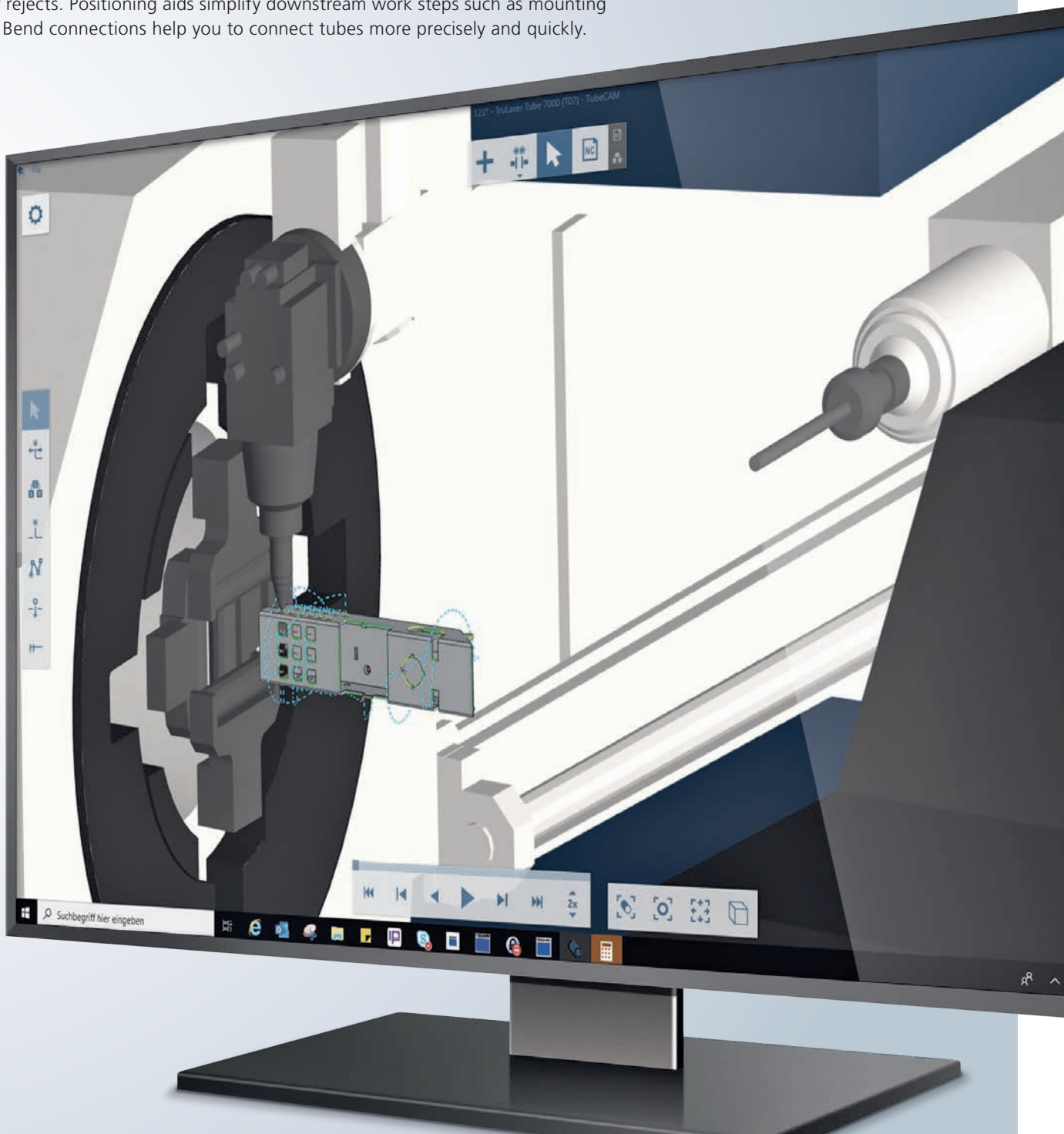

Functions that take you forward

With clever functions and integrated expertise, your TruLaser Tube simplifies the route of your tubes and profiles throughout the machine. From loading to cutting and unloading to downstream processes, the purpose is clear: to help you build on your competitive edge.



- **Safe and automatic loading** even of special profiles – Smart Profile Detection detects the position and orientation of the profile with the help of sensors, and adapts the cutting program accordingly.
- **Automatic tube alignment** is carried out by SeamLine Tube. It detects weld seams or markings and aligns the tube suitable to the cut geometry.
- **Quick and efficient manufacturing of small lot sizes** is facilitated by the pivoted manual conveyor system. Loading is automatic and also perfectly suited to special profiles.



- **Productive manufacturing of material thickness up to 0.125 in.** using the function RapidCut. It uses the high-feed rates of the solid-state laser even with small contours, allowing you to process your parts up to 30% faster.
- **Reduce piercing times** with PierceLine, depending on the material type and thickness, by 10–60% compared to preset values.
- **One cutting head for all wall thicknesses** is all you need thanks to the single cutting head strategy of TRUMPF.
- **Protect the cutting head and avoid collisions** using the ControlLine function – the distance between the cutting nozzle and the surface remains constant, even with uneven tube surfaces. The magnetic coupling minimizes the impact of unavoidable collisions.
- **Reduce rejects and material costs** with the help of AdjustLine. It helps you cut even lower quality material quickly and easily.
- **Adapt the focus position to the material type and thickness** using the automatic FocusLine function.



- **Sort parts according to orders** with the help of wire mesh boxes, customer-specific containers, or conveyor tables which protect your materials.
- **Automate loading and unloading even further** using the digital unloading interface, for example by connecting a robot.



- **Prepare bevel edges optimally** using the bevel cut function with patented TRUMPF technology for high-quality bevel cuts up to 45°.
- **Apply threads in a single work step** using the technology package for tapping directly on your machine. Using an NC-controlled spindle unit, you can carry out processes such as twist drilling, thread cutting, flow drilling, and tapping.
- **Clean inside of tubes** are ensured by the spatter protection device for round tubes, avoiding the need for reworking.
- **Identify your parts** easily using a Dot Matrix Code.

The right machine for you

Laser tube cutting requires advanced technology, coordinated components, and a service network at your side. That's why, at TRUMPF, we develop the machine, laser, software, and automation in-house. We manufacture all the important components for the machining process ourselves, making sure you get the best possible results.

Which machine meets your requirements? Find out more about the TruLaser Tube family on the following pages.



Find out more information here about our laser tube cutting product portfolio:
https://www.trumpf.com/en_INT/products/machines-systems/laser-tube-cutting-machines/





TruLaser Tube 3000 fiber

The machine that's always worth it for laser tube cutting.

01

Cost-effective

even when it is not fully utilized

02

Reliable

thanks to robust design and intelligent functions

01

Cost-effective

even when it is not fully utilized

Whether you want to ensure quality, take advantage of flexible manufacturing to meet tight deadlines, or want to win new customers and markets: this machine pays for itself, even if you don't utilize it fully.

02

Reliable

thanks to robust design and intelligent functions

No need for time-consuming manual setting of the machine that is more likely to cause errors, as the machine automatically performs many of the tasks itself. It uses ControlLine to avoid collisions and AdjustLine to cut lower quality material safely. Thanks to FocusLine, the focus is always in the right place.



Max. outside diameter of round tube: 6 in.
 Max. outer circle diameter of rectangular tube: 6.7 in.
 Max. workpiece weight in lbs/ft: 12.5 lbs/ft (265 lbs/ 330lbs total)

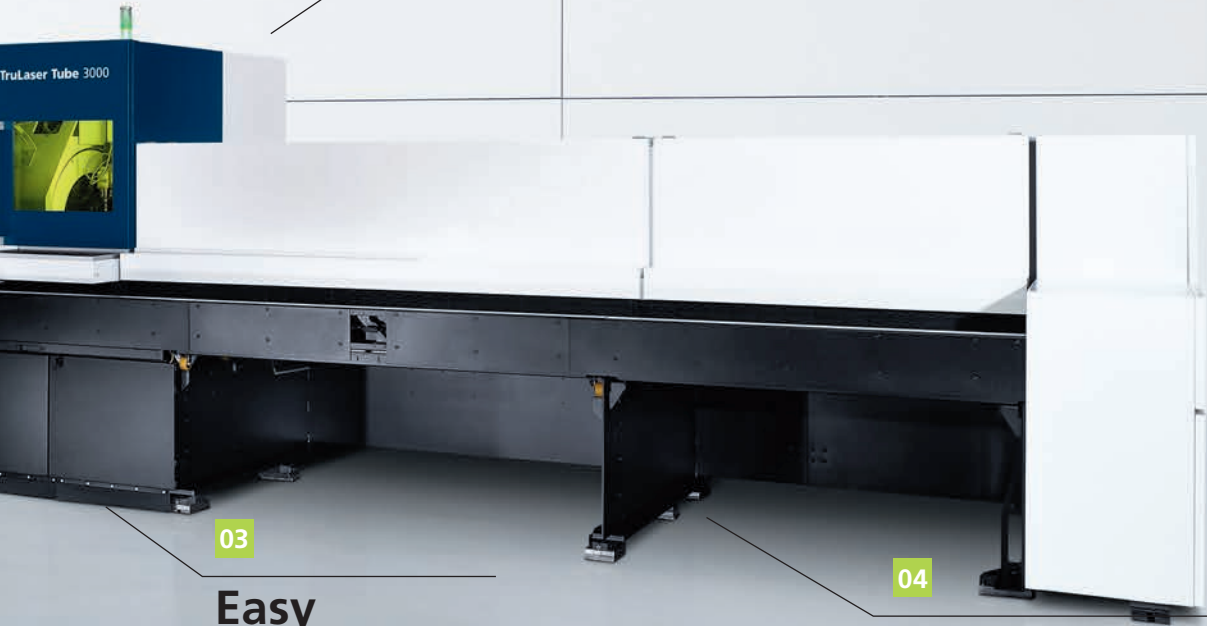

03

Easy
to handle

04

Precision
cutting and clamping

03

Easy
to handle

Easy to operate: minimal setup times, outstanding accessibility – so that you never lose sight of the process. Loading and unloading can easily be carried out manually or automatically using Load-Master Tube, crane, or part removal flap.

04

Precision
cutting and clamping

Its precision matches that of the 5000 and 7000 series: high-precision clamping system, exact optics setup and precise tube guidance for best part quality. Thanks to the adaptive clamping system, you can process L- and U-profiles yourself.

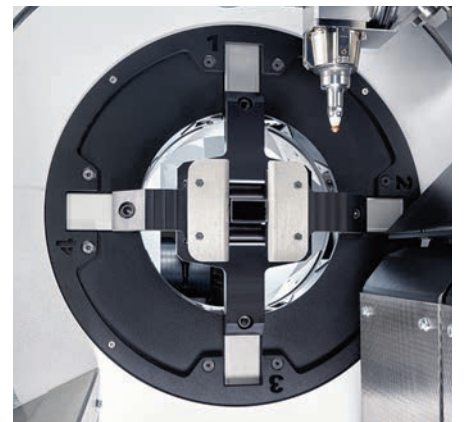

More information about the TruLaser Tube 3000 fiber can be found here:
https://www.trumpf.com/en_INT/products/machines-systems/laser-tube-cutting-machines/tru-laser-tube-3000-fiber/



TruLaser Tube 5000 fiber

Solid-state laser technology for fast and flexible processing. The TruLaser Tube 5000 fiber uses these strengths more than any other laser tube cutting machine has ever done before.



01

Highly productive

with solid-state laser and Rapid-Cut

02

Setup time

virtually zero

01

Highly productive

with solid-state laser and RapidCut

Thanks to RapidCut, the high feed rates of the solid-state laser come into their own even with smaller contours. With thin material in particular, this is a huge productivity advantage.



With RapidCut, you can reduce part cutting times for material thicknesses of up to 0.125 in..

02

Setup time

virtually zero

Setup is so outmoded – the clamping system of the TruLaser Tube 5000 fiber lets you produce tubes in the entire clamping range with no setup.

Max. outside diameter of round tube: 6 in.
 Max. outer circle diameter of rectangular tube: 6.7 in.
 Max. workpiece weight in lbs/ft: 13.5 lbs (290 lbs/355 lbs total)



04

Easily expandable

for follow-up processes such as tapping

03

Perfectly accessible

thanks to intelligent beam guard

03

Perfectly accessible

thanks to intelligent beam guard

Tube processing by solid-state laser is not only possible with a complete housing – but the open machine concept makes your TruLaser Tube 5000 fiber optimally accessible. Load and unload individual tubes quickly and easily from the front.



04

Easily expandable

for follow-up processes such as tapping

Easily integrate further processes: With the technology package for tapping, you can carry out machining processes such as flow drilling, tapping, and twist drilling. In the laser network, you can operate several TRUMPF machines with one laser.



More information about the TruLaser Tube 5000 fiber can be found here:
https://www.trumpf.com/en_INT/products/machines-systems/laser-tube-cutting-machines/tru-laser-tube-5000-fiber/



TruLaser Tube 7000 fiber

Highest level of productivity –
even for XXL tubes.



01

Dynamic and productive

with solid-state laser and RapidCut

02

XXL

tubes up to 10 in. diameter

01

Dynamic and productive

with solid-state laser and RapidCut

The superimposed movement of the tube axis and cutting head increases the dynamics of your machine by more than four times. Thanks to RapidCut, the high feed rates of your solid-state laser come into their own even with smaller contours. With thin material in particular, this is a huge productivity advantage.



With RapidCut, you can increase the acceleration by up to four times.

02

XXL

tubes up to 10 in. diameter

Whether large or small, thick or thin: With your TruLaser Tube 7000 fiber you can cut a broad spectrum of parts. This includes even extra-large tubes and profiles with diameters up to 10 in., and wall thicknesses of up to 0.5 in. for mild steel.

*For manual loading total weight max. 27 lbs/ft.

Content subject to change without notice. Only specifications in our offer and order confirmation are binding.

Max. outside diameter of round tube: 10 in.
Max. outer circle diameter of rectangular tube: 10 in.
Max. workpiece weight in lbs/ft: 27 lbs (500 lbs/810 lbs total)

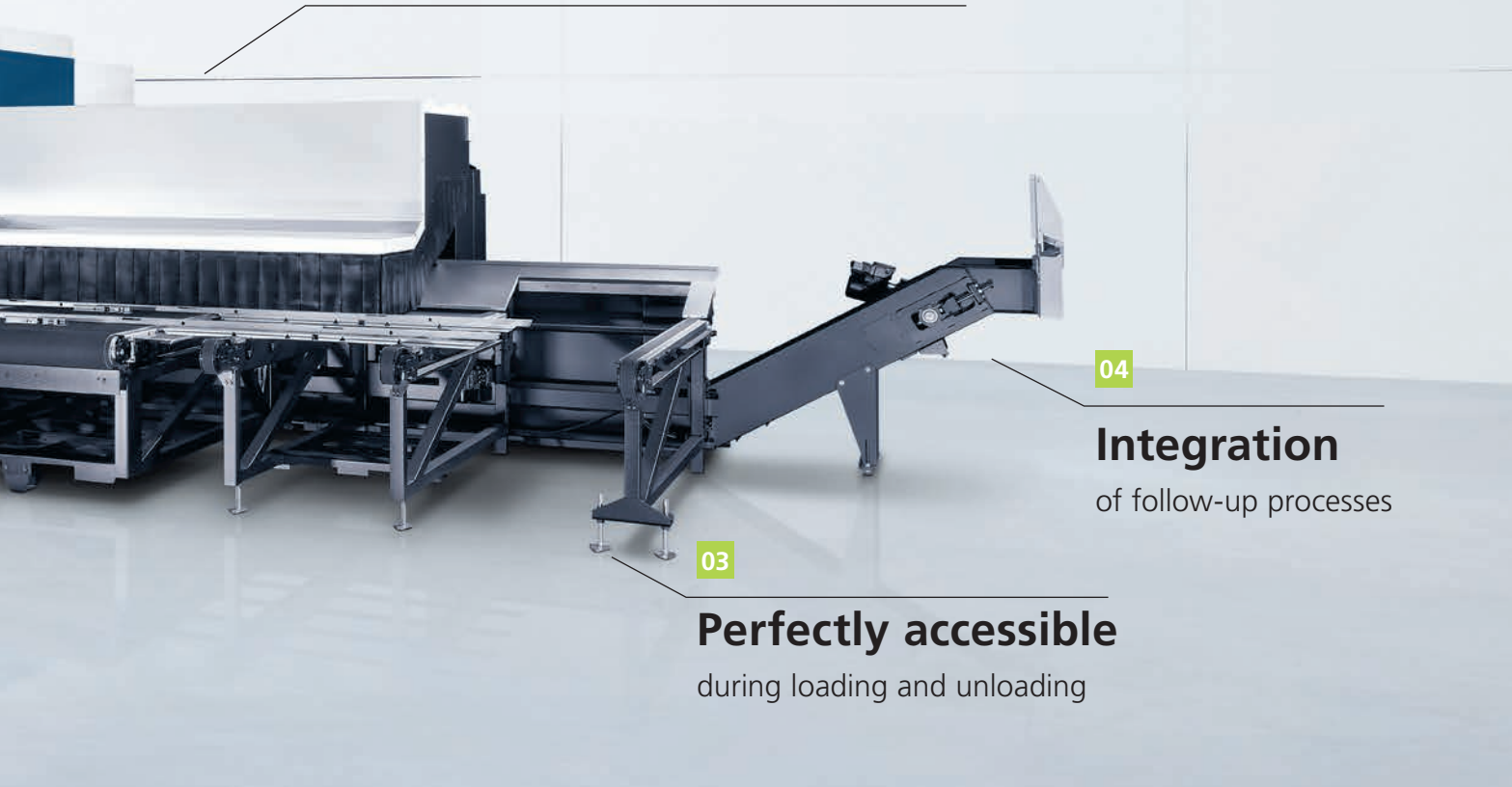

04

Integration
of follow-up processes

03

Perfectly accessible
during loading and unloading

03

Perfectly accessible
during loading and unloading

The open machine concept makes your TruLaser Tube 7000 fiber optimally accessible. This allows you to load individual XXL tubes – for example by crane – quickly and efficiently. For small lot sizes and special profiles you can use the swivel-mounted conveyor system.



04

Integration
of follow-up processes

Carry out follow-up processes on your machine with ease: With the optional technology package for tapping, for example, you can execute machining processes such as flow drilling, tapping, and twist drilling – automatically.



More information about the TruLaser Tube 7000 fiber can be found here:
https://www.trumpf.com/en_INT/products/machines-systems/laser-tube-cutting-machines/tru-laser-tube-7000-fiber/



Technical data

Here is the technical data for our TruLaser Tube machines and an overview of the availability of intelligent functions.

Laser data		TruLaser Tube 3000 fiber	TruLaser Tube 5000 fiber		TruLaser Tube 7000 fiber
		TruFiber 2001	TruDisk 3001	TruDisk 4001	TruDisk 4001
Max. power	kW	2	3	4	4
Average power input in production	kW	6	9	11	11
Max. material thicknesses					
Mild steel	in	0.313	0.375	0.500	0.500
Stainless steel	in	0.188	0.250	0.313	0.313
Aluminum	in	0.188	0.250	0.313	0.313
Copper/brass	in	0.125	0.188	0.188	0.188

Content subject to change without notice. Only specifications in our offer and order confirmation are binding.

Available functions/options	TruLaser Tube 3000 fiber	TruLaser Tube 5000 fiber	TruLaser Tube 7000 fiber
AdjustLine	■	■	■
Digital loading and unloading interface	■	■	■
Dot Matrix Code	■	■	■
Conveyor system	■ (nonswiveling)	■ (nonswiveling)	■ (swiveling)
Magnetic coupling/Controlline/FocusLine	■	■	■
PierceLine		■	■
RapidCut		■	
Bevel cut		■	■
SeamLine Tube	■	■	■
Smart Profile Detection		■	■
Sorting function unloading point			■
Spatter protection device			■
Technology package for tapping		■	■

TruLaser Tube 3000 fiber		
Max. outside diameter of round tube	in	6 ^[1]
Max. outer circle diameter of rectangular tube	in	6.7
Max. unprocessed material length for automatic loading	in	256 315 ^[2]
Max. finished part length	in	120 180 ^[2]
Max. workpiece weight	lbs/ft	12.5 (265 330 lbs total) ^[2]
Available lasers		TruFiber 2001

Content subject to change without notice. Only specifications in our offer and order confirmation are binding.

TruLaser Tube 5000 fiber		
Max. outside diameter of round tube	in	6 ^[1]
Max. outer circle diameter of rectangular tube	in	6.7
Max. unprocessed material length for automatic loading	in	256 315 ^[2]
Max. finished part length	in	180 240 ^[2] 256 ^[2] 315 ^[2]
Max. workpiece weight	lbs/ft	13.5 (290 355 lbs total) ^[2]
Available lasers		TruDisk 3001 TruDisk 4001

Content subject to change without notice. Only specifications in our offer and order confirmation are binding.

TruLaser Tube 7000 fiber		
Max. outside diameter of round tube	in	10
Max. outer circle diameter of rectangular tube	in	10
Max. unprocessed material length for automatic loading	in	256 362 ^[2]
Max. finished part length	in	180 240 ^[2] 256 ^[2] 315 ^[2]
Max. workpiece weight	lbs/ft	27 (500 810 lbs total) ^[3]
Available lasers		TruDisk 4001

Content subject to change without notice. Only specifications in our offer and order confirmation are binding.

^[1] Manual loading of round tubes with outside diameter of 6 to 6.7 in. optionally possible. ^[2] Value for the longer finished part length design (option). ^[3] For manual loading total weight max. 27 lbs/ft..

TruServices. Your Partner in Performance

To ensure your future success, you need services that definitely put you ahead of the pack over the long term. Whether that means creating the best conditions for successful production or optimally using your TRUMPF laser tube cutting machine to adapt to changes with flexibility – together we will find ways to sustainably maximize your value creation. As a reliable partner, we will provide you with comprehensive solutions and service packages for your requirements – so that you can produce cost-effectively and at a constantly high level.

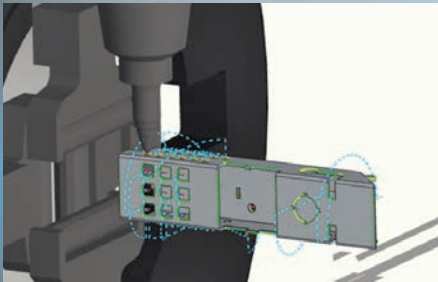

EMPOWER: If you want to create the best conditions for successful manufacturing: We will support you in this. The software system Programming Tube enables you to automatically create programs for your tube and profile designs. The easy-to-use programming makes your laser tube cutting machine especially productive.



SUPPORT: If you want to gradually gear your manufacturing to maximum value creation: We will work together to reach your goal. Use our comprehensive training program to expand your knowledge and get a competitive edge. Our experienced trainers share their tips and tricks when it comes to your TruLaser Tube machine and take you to the next level in the field of laser tube cutting.

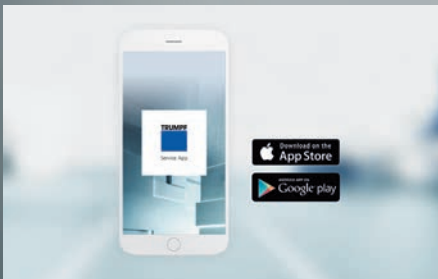

IMPROVE: If flexibility and availability of equipment in day-to-day operations are essential to you: We are there for you. Technical Service and the TRUMPF service network will assist you with any questions about your TruLaser Tube. Simply contact us, including using the Service app.



Financing

Training Courses

Pre-owned Machines

Technical Service

Tools

Genuine Parts

Design and Programming Software

Process Optimization

Monitoring & Analysis

Product Enhancements

Value Packages

Service Agreements



Learn more here about our complete and comprehensive package of useful services: www.trumpf.com/s/services



TruConnect – Your Smart Factory

Gain more freedom with digital networking: You see more, know more, and get the best out of your production. With TruConnect, the synonym for Industry 4.0 at TRUMPF, you can design your Smart Factory step by step. The solutions from TRUMPF support you on your path towards your networked production, helping you to make the entire process more transparent, more flexible, and above all, more efficient.

For companies big and small

From the simple product solution right through to fully networked production

- **Start simply** with machines that are equipped for networking as standard.
- **Customize step by step** with automated machines or autonomous processing cells embedded in a production solution.
- **Enjoy full networking** with a continuous production solution, from order to delivery.

Smart functions and Industry 4.0

Due to the Central Link interface, your TruLaser Tube machine is ready for Industry 4.0. In addition, it contains various TRUMPF Machine Apps, which can be used to analyze and display machine data. This provides transparency – and shows you exactly where you can optimize processes.



80%

Indirect processes make up 80% of your production time – this is where the greatest potential for saving lies.



Discover what potential networked production offers you with two example scenarios: www.trumpf.com/s/smart-factory

Passion is what drives us

Whether it's production and manufacturing technology, laser technology, or material processing – we develop highly innovative products and services which are suitable for industry and absolutely reliable. We put everything we've got into giving you a compelling and competitive edge – expertise, experience, and a lot of passion.



Check out our
YouTube page:
www.youtube.com/TRUMPFtube
www.trumpf.info/97b623

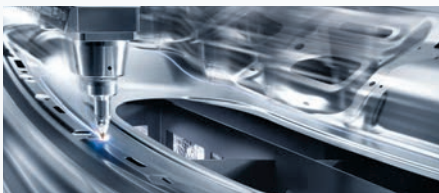

Lasers for manufacturing technology

Whether on a macro-, micro-, or nanolevel – we have the right laser and the right technology to produce innovatively and cost-efficiently in every industrial application. Beyond the technology itself, we support you with system solutions, application knowledge, and advice.

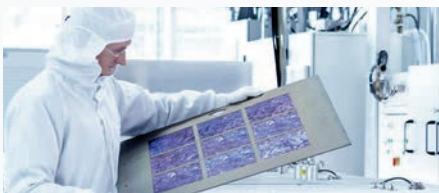

Power supplies for high-tech processes

From semi-conductor manufacturing to solar cell production: with our RF and MF generators, the current for induction heating, plasma and laser excitation is given a defined frequency and power – with high reliability and repeatability.



Machine tools for flexible sheet and tube processing

Whether it's laser cutting, punching, bending, or laser welding: we offer tailor-made machines and automation solutions, including consulting, software, and services for all processes in flexible sheet metal processing – so you can reliably manufacture your products to exacting quality standards.



Industry 4.0

The TruConnect range of solutions links human and machine with information. It covers all steps in the production process – from the offer right through to the shipping of your parts.

TRUMPF is certified to ISO 9001
(Find out more: www.trumpf.com/s/quality)

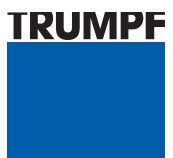

TRUMPF Werkzeugmaschinen GmbH + Co. KG
www.trumpf.com