

Marvel®

Quality Machines

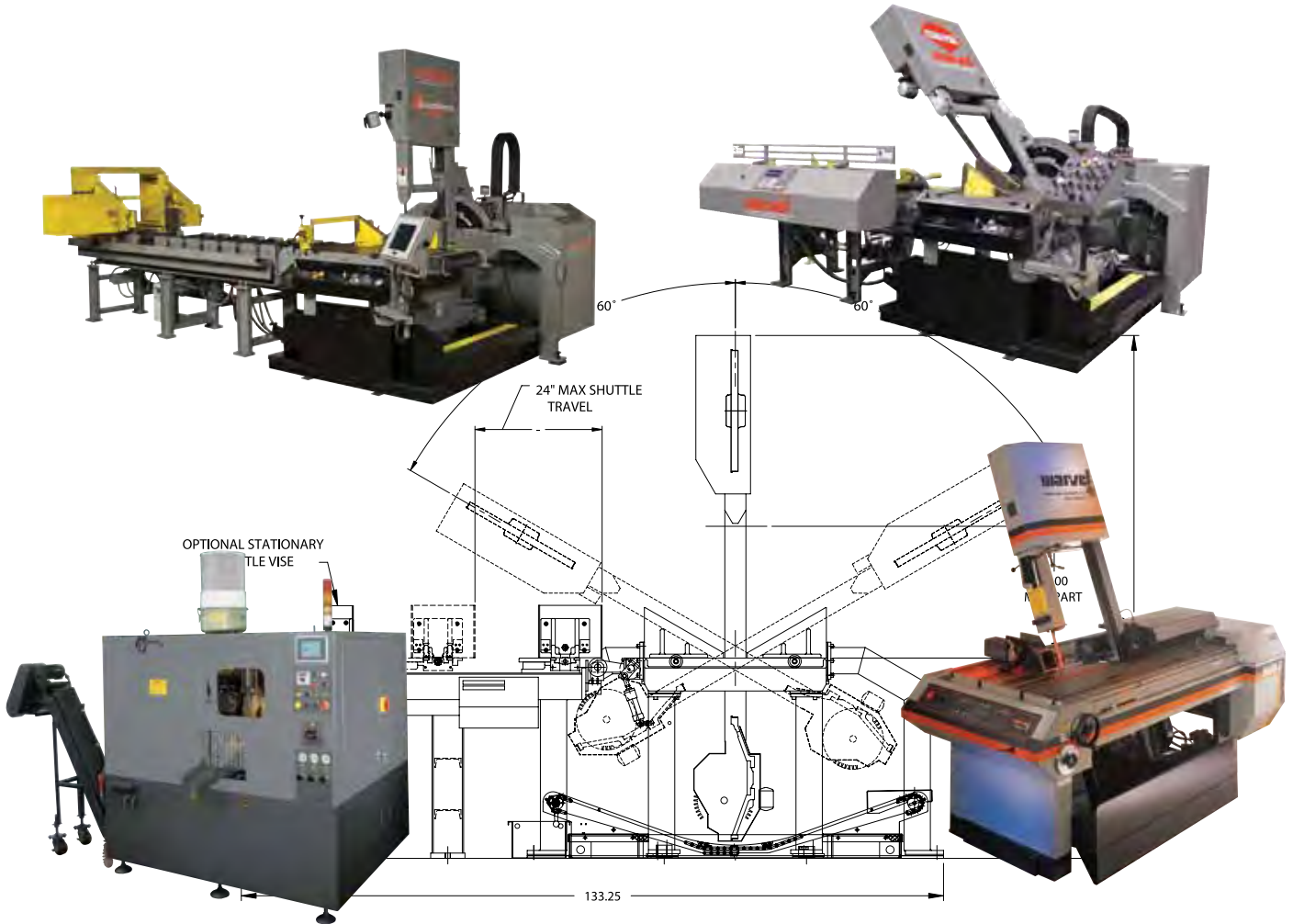

SPARTAN®
by **Marvel®**
MANUFACTURING COMPANY, INC.





Series 8 Mark III

Miter cuts up to 60° with optional power column tilt. Column adjustable from 90° to 3° canted.

- Capacity: 18" X 22" (457mm x 560mm)
- at 45° 18" x 14.5" R, 13" L (457mm x 368mm R, 330mm L)
- at 60° 18" x 9.7" R, 7.3" L (457mm x 246mm R, 185mm L)
- Blade Speed: 50-450 FPM (15-137m/min)
- Feed: 0-250 lbs (0-64kgf)
- Motor: 5 H.P. (3.85kw)
- Blade: 15'4" x 1.25" x .042 (4674mm x 32mm x 1.07mm)
- Shipping Weight: 2900 lbs (1315kg)



Series 8 Mark II

A truly universal machine capable of making virtually any conceivable straight or miter cut (45° right & left). Available in both standard and high column models with or without the optional 3° column. All mechanical.

- Capacity: 18" x 22" (457 mm x 560 mm)
- at 45°: 18" x 12-3/4" (457 mm x 324 mm)
- Blade Speed: 50-450 FPM (15-137 m/min)
- Feed: 0-140 lbs (0-64 kgf)
- Motor: 2 H.P. (65 kw)
- Blade: 14' 6" x 1" x .035" (4420 mm x 25 mm x .89 mm)
- Shipping Weight: 2870 lbs (1300 kg)

Series 2125 & Series 2150 TouchTech 60

High-production, versatile, large capacity 60° mitering bandsaw. Standard features include Touchscreen Cutting Edge Control, 3° canted saw frame, 60° mitering both right and left, vector electric blade drive, 1-1/4" or 1-1/2" blade, and servo-drive automatic bar feed with 48" index. Extended feed length to 18' available.

- Capacity: 20" x 25" (508 mm x 635 mm)
- Blade Speed: 30 - 650 FPM (9 - 200 m/min)
- Feed: 0-350 lbs. (0-1560N)
- Motor: Series 2125: 7.5 H.P. (5.6 kw)
Series 2150: 10 H.P. (7.5 kw)
- Blade: Series 2125: 17' 6" long x .042 x 1.25"
Series 2150: 18' 2" long x .050 x 1.50"
- Shipping Wt: 8480 lbs. (3846 kg)



Series 2125A-PC60, 2150A-PC60, 2125M-60, 2150M-60

High production, versatile, large capacity 60° mitering, both right and left, bandsaw. Standard features include: Marvel PCII controls (PC) or Manual (M), 3° canted saw frame, vector electric blade drive and automatic bar feed with 48w" index length.

- Capacity: 20" x 25" (508 mm x 635 mm)
- Blade Speed: 30 - 475 FPM (9-145 m/min)
- Motor: 7.5 H.P. (5.6 kw)
- Blade: Series 2125: 17' 6" long x .042 x 1.25"
Series 2150: 18' 2" long x .050 x 1.50"
- Shipping Wt: 7000 lbs. (3175 kg)





Series 380A-PC60

The 380 offers productivity in a slightly smaller package, combining many of our most popular features such as 60° mitering, patented Easy-Load blade guides, quick change adjustable column cant and our 48 inch double ball screw automatic bar feed with high speed travel for faster cycle times. Additional features include linear ways on the column, bar feed and guide arm as well as two exciting new innovations; **Direct Force Sensing Electric Feed** and the **Marvel PC3 Programmable Control**.

Capacity: 15" x 20" (381 mm x 508 mm)
 Blade Speed: 60 to 400 FPM (18 to 122 m/min)
 Motor: 5 H.P. (3.75 kW)
 Blade: 16' long x 1.25" wide x .042" (4877 x 1.07 x 32 mm).

Series 25 & 25APC

The Series 25 is Marvel's largest high speed, heavy duty vertical band saw. It is designed for fast, easy overhead loading—the counterbalanced column tilts 45° left and right for added versatility. The Programmable Control allows for easy and quick set up of jobs. 3° column is standard.

Capacity: 24" x 35" (610 mm x 889 mm)
 45° Right: 24" x 23.5" (610 mm x 597 mm)
 45° Left: 24" x 21" (610 mm x 533 mm)
 Blade Speed: 60-400 FPM
 Feed: 0-350 lbs (0-159 kgf)
 Motor: 15 H.P. (11kW)
 Blade: 20' 4" x 1-1/2" x .050 (6197.4mm x 41mm x 1.27mm)
 Shipping Weight: 25: 12,000 lbs (5,443kg) 25APC :15,500 lbs (7,250 kg)



Marvel PC3

The Marvel PCII brings the accuracy, speed, and versatility of programmable cutting to nearly every Marvel and Spartan band saw. It stores as many as 99 jobs in memory and has built in self-test and diagnostics. Easy to operate, having inch and metric capability.



Windows NT® Touch Screen Control

The TouchTech Cutting Edge control incorporates Windows NT software and conversational programming. This new control combines ease of operation with increased flexibility and customization. Programming of automatic jobs includes an illustration of the finished part. Operators can choose either factory presets for blade speed and tilt angle, or customized settings for their specific needs. The TouchTech control is available on both the 2125 and 2150 Series machines.



EPC Control

The Spartan EPC Programmable control is available on all Spartan Horizontal Production Band Saws. This user friendly touch screen control allows the operator to quickly and easily program and store up to nine jobs.

Material Handling

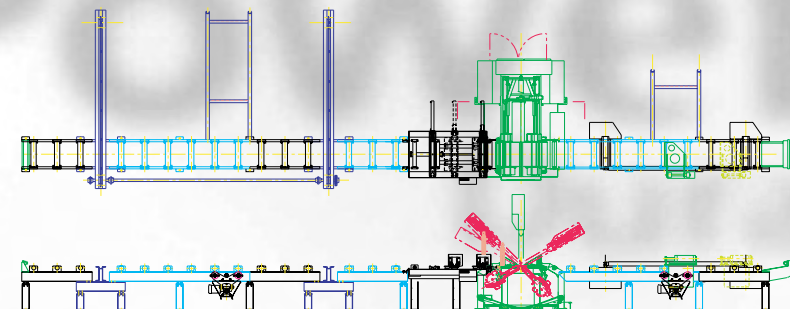

Marvel, a leader in integrated material handling systems, offers a wide variety of options to meet the high demand for increased cutting efficiencies. The turn-key, fully integrated material handling systems can be included to serve one or multiple machines. One can choose from a wide range of features that can include: powered or dead roller tables, several styles of material loading systems, cut material ejectors with storage tables and programmable positioned gauging. All systems are custom designed to meet your specific requirements.



Industrial Production Saws



Automatic Horizontal Band Saws

Spartan horizontal band saws are available in five different models, with round capacities ranging from 10" to 28". All machines are designed for high production, fully automatic cutting applications. Standard features on all models include: full stroke vises, hydraulic blade tension, infinitely variable blade speeds with electric tachometer, digital length settings, multi-index, piece counter, out of stock switch, motion detector, fast approach, work light and powered blade cleaning brush.

Model:	Capacity Rounds:	Blade Width:
PA-10/3	10" (250 mm)	1" (25 mm)
PA-13/3	14" (356 mm)	1-1/4" (32 mm)
PA-18/3	18" (457 mm)	1-1/2" (41 mm)
PA-22	22" (560 mm)	2" (50 mm)
PA-28	28" (700 mm)	2" (50 mm)

Double Column Saws

Our double column band saws feature straight and miter cutting with capacities from 20" to 80" and blade sizes from 1-1/2" to 3". Some models include powered moveable guide arm, out of square protection, dual vising, variable blade speed, and a stock positioning hydraulic shuttle table. Standard features include: hydraulic blade tensioning, motion detector, hydraulic down feed, roller bearing and hydraulically actuated carbide blade guides, cut line indicator, and vibration dampening bar. For structural cutting, a swivel machine is available with a base that swivels both ways.

Model:	Capacity:	Blade Width:
PB-2022	20" x 22"	1-1/2" (41mm)
PB-2828	20" x 28"	2" (54mm)
PB-2840	28" x 40"	2" (54mm)
PB-4043	40" x 43"	3" (80mm)
PB-5252	52" x 52"	3" (80mm)
PB-5263	52" x 63"	3" (80mm)
PB-6363	63" x 63"	3-1/8" (80mm)



PA460HD

This rugged twin post machine specifically designed to cut speciality steels. Features include rigid construction, 10H.P. blade drive, vibration dampening system and split front vise jaws that hold remnants to as little as 3 inches.

Capacity: 20" x 18" (500mm x 460mm)

Blade Speed: 65-330 FPM (20-100 m/min.)

Motor: 10 H.P. (7.5kw)

Blade: 17'11" x 1.5" x .050" (5450mm x 41mm x 1.3mm)

Weight: 8000 lbs (3629 kg)



Ironworkers

Spartan Ironworkers offer excellent value with impressive capacities in punching, flat bar shearing, angle shearing, bar shearing, notching, and special tooling. All of the two cylinder Spartan Ironworkers now offer an electric backgauge as standard equipment. Full control foot pedals, see-through stripper, and two hole die holder (D & DX series only) are only a few of the standard features available on Spartan Ironworkers. 20" throat models available (DX).

Model	Capacities
IW 50	50 Tons
IW 50S	50 Tons
IW 66	66 Tons
IW 66D	66 Tons
IW 88D	88 Tons
IW 110D/2	110 Tons
IW 135D	135 Tons
IW 180DX	180 Tons

A full line of Single End Punching Machines are also available up to 220 tons.



Hercules S330/2

Economical and versatile, this horizontal swivel head machine offers miter cutting capability from -45° to +60°.

Capacity:	12" x 18" (300 mm x 460 mm) 13" Round
at 45°:	11" x 12" (280 mm x 300 mm) 12" Round
at 60°:	11" x 8" (280mm x 203mm) 9.5" Round
Blade Speed:	90/140/220/320 SFPM
Motor:	2 H.P. (1.5 kw)
Blade:	13' 6" x 1" x .035"
Shipping Wt:	2900 lbs. (1315 kg)



Contour Saws

Spartan Contour saws are available with either 20" (500 mm), or a 36" (914 mm) throat capacity and are equipped with a stationary table that can be tilted 45° right and 10° left for miter work. All models feature standard equipment including the welder, annealer, grinder, blade shear, work light, chip blower, and blade tension indicator. These machines are designed for rugged performance on a wide variety of materials at a minimum cost.

Blade Speed:	Low: 50 fpm, High: 5000 fpm
Motor:	3 H.P. (65kw)
Blade Width:	1/8"-1" (3.18 mm-25 mm)



Carbide Circular Automatic Saws

High speed production carbide circular saw. Ideal for 90° cuts on solid or heavy wall material providing extreme accuracy and finish. Standard features include touch-screen controls, servo driven ball screw feed, servo drive automatic bar feed, automatic loading table, hydraulic discharge chute, carbide blade guides, chip conveyor, air filter, mist type coolant system, and inverter control blade speeds.

Model:	Capacity Rounds:	Blade Diameter:
P-65B	2-1/2" (65 mm)	11" (280 mm)
P-100B	4" (100 mm)	14" (360 mm)
P-150B	6" (150 mm)	18" (460 mm)



Plate Saws

Heavy Duty Construction and large capacity vertical plate saw. Standard features include space saving moveable saw head, precision linear ways, hydraulically positioned saw guide arm, hydraulic blade tension, AC servo/feed, programmable feed and blade speed settings, rapid approach and return of saw head, motion detector, automatic feed adjustment, on-screen self diagnostic, out-of-square detector, and automatic chip conveyor.

Capacity	Blade Size	Table Length
16" x 20"	1-1/2"	5' & 8'
28" x 28"	2"	5' & 8'
16" x 28"	1-1/2"	10', 15' & 20'
28" x 40"	2"	10', 15' & 20'
40" x 52"	2-5/8"	10', 15' & 20'
52" x 63"	3"	10', 15' & 20'



Marvel Mfg. Co.

Marvel has been designing and manufacturing sawing equipment for more than 100 years. We carry on this proud tradition today to assure that every piece of equipment we offer is of the highest quality and workmanship.



Visit our website for more detailed information on the products we offer or call 1-800-4-SAWING.



Corporate Office and Manufacturing Facility
3501 Marvel Drive
Oshkosh, WI 54902
Phone: 1-920-236-7200
Toll free: 1-800-472-9464
Fax: 1-920-236-7209
Email: abinfo@marvelsaws.com

www.marvelsaws.com

Some safety equipment may have been removed or opened to illustrate products clearly and must be in place, and functioning, prior to operation. Specifications are subject to change without notice.

© 2009 Marvel Mfg. Co. Inc.